

MSR42 Micro 400 Controller/Muting Module

Description

The MSR42 multi-function safety relay is the control module for the GuardShield Micro 400 safety light curtain, but can also be used with any light curtain. This versatile Category 4 safety device has a pair of PNP solid state, 400 mA OSSDs for direct connection to the final switching device. When safety relay outputs are required, the MSR42 easily accommodates the interconnection of up to three MSR45E safety relay expansion modules, each providing a pair of safety relay outputs. Simply connect ribbon cable connectors from the back of the MSR42 to each of the MSR45E modules for a series of interconnections for two PNP OSSDs, and six N.O. relay outputs.

The MSR42 has four software configurable inputs. These configurable safety inputs allow the connection of a multitude of safety devices such as safety light curtains, safety laser scanners, e-stops, safety switches, etc.

This 22.5 mm DIN mount multi-function safety module has both hard wired and software configurable operating modes. The removable spring terminal connectors on the MSR42 allow for ease of wiring of the device as well as hard-wired operating mode configuration.

Manual/automatic reset and start/restart can be configured by simply changing the wiring (see basic configuration examples).

Features such as two or four sensor muting, connecting up to two additional safety light curtains or other safety devices and configuring one or two auxiliary outputs are easily configured using the optical interface with the supplied software.

The MSR42 and Micro 400 light curtains support fixed blanking which is only available in the basic configuration mode and configured through a "teach-in" selector switch via the GPIO pins.

Features

- Category 4 per EN 954-1
- SIL CL3 IEC 61508, IEC 62061
- 22.5 mm housing
- Stop category 0, 1
- 24V DC supply voltage
- Manual, monitored or automatic reset
- Thirteen diagnostic LEDs
- Unique design allows for easy addition of relay expansion modules
- Removable terminal blocks
- One or two configurable auxiliary, standard outputs
- Connection of one or two additional safety devices
- RJ45 connections for Micro 400 safety light curtain
- Two or four sensor muting (Micro 400 only)
- Fixed blanking (Micro 400 only)
- Two sensor muting all GuardShield light curtains
- Supports up to three MSR45E expander units
- Free configuration software can be downloaded at www.ab.com/safety



Specifications

Safety Ratings	
Standards	EN 954-1, IEC/EN 60204-1, IEC 61496-1
Safety Classification	Cat. 4 per EN 954-1 (ISO 13849-1), SIL CL3 per EN IEC 61508, PLe per ISO 13849-1
Functional Safety Data * Note: For up-to-date information, visit http://www.ab.com/safety/	PFH _D : < 9.00E-10 MTTFd: > 331 years For use in SIL3 systems (according to IEC 61508) depending on the architecture and application characteristics
Certifications	CE Marked for all applicable directives, cULus, and TÜV
Power Supply	
Input Power Entry	24V DC
Power Consumption	2.4 W (semi-conductor outputs unloaded)
Inputs	
Safety Inputs	2 N.C. or 2 OSSD, Micro 400 software selectable
Input Resistance, Max.	—
Reset	Auto./manual or manual monitored
Power On Delay Time	Determined by configuration
Response Time	Determined by configuration
Outputs	
Safety Contacts	2 PNP, 400 mA each
Auxiliary Contacts	2 PNP, configurable
Environmental and Physical Characteristics	
Enclosure Type Rating/ Terminal Protection	IP20/ IP20
Operating Temperature [C (F)]	0...55 ° (32...131 °)
Vibration	0.35 mm 10...55 Hz
Mounting	35 mm DIN Rail
Weight [g (lb)]	130 (0.287)
Conductor Size, Max.	1 x 2.5 mm ² (14 AWG) stranded

* Usable for IEC 62061. Data is based on the following assumptions:
- Mission time/Proof test interval of 20 years

LED Indicators (Basic Configuration) * ‡

LED	Green	Red
Lamp	—	—
GPI04	Automatic start	Manual start (off)
GPI03	Manual or automatic start	Manual start (off)
GPI02	Configurable	Configurable
GPI01	Configurable	Configurable
OSSD2	Output active	Output inactive
OSSD1	Output active	Output inactive
Info2 (LED)	Configurable	Configurable
Info1 (LED)	Configurable	Configurable
IN2	Start release	No start release signal
IN1	No test input	Test input
0V	—	—
+24V	Power connected	No power connected

* All I/O is configurable except OSSD1 and OSSD2.

‡ LED behavior depends on configuration (see instruction sheet for details).

Product Selection

Inputs	Safety Outputs	Auxiliary Outputs	Terminals	Reset Type	Power Supply	Cat. No.
GuardShield Micro 400 and 4 x GPIO	2 PNP	2 PNP, configurable	Removable	Auto./manual or manual monitored	24V DC	440R-P226AGS-NNR

Approximate Dimensions

Dimensions are shown in mm (in.). Dimensions are not intended to be used for installation purposes.

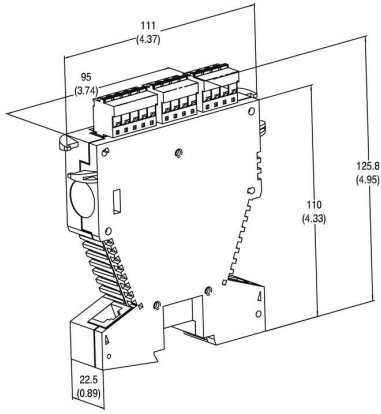

Accessories

Description	Cat. No.
MSR45E—Safety Relay for MSR41 or MSR42 (requires ribbon cable connection)	440R-P4NANS
Ribbon cable—for one MSR45E	440R-ACABL1
Ribbon cable—for two MSR45Es	440R-ACABL2
Ribbon cable—for three MSR45Es	440R-ACABL3
Replacement terminal block kit—MSR42	440R-ATERM2P
Replacement terminal block kit—MSR45E	440R-ATERM2C
USB optical interface software configuration tool used to configure the MSR42	445L-AF6150
Replacement suction cup	445L-AF6151
Optical interface fastener	445L-AF6152

Typical Wiring Diagrams

Basic Configurations (No Software)

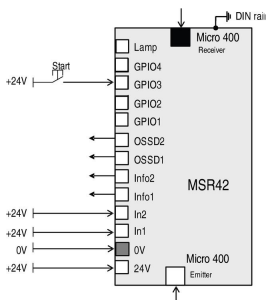

Micro 400 Light Curtain, Manual Reset, No Output Monitoring

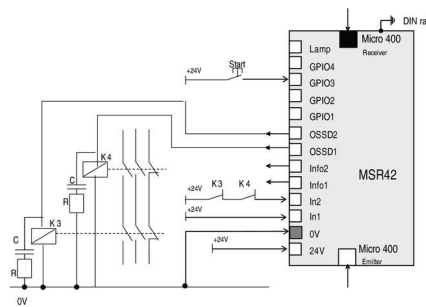

Micro 400 Light Curtain, Manual Reset, Start/Restart Monitored Output

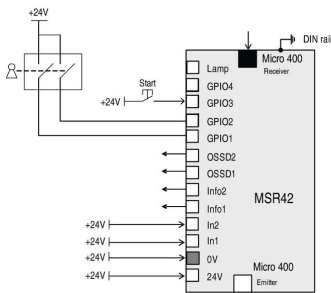

Fixed Blanking, Micro 400 Light Curtain, Manual Reset, No Output Monitoring

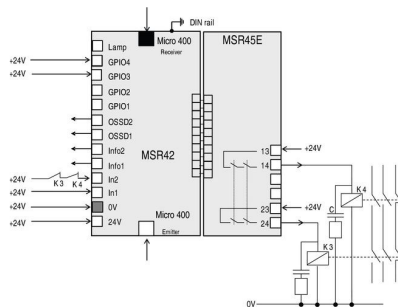

Micro 400 Light Curtain, Automatic Reset, Start/Restart Monitored Output and MSR45E Expansion Module

Software Configurations

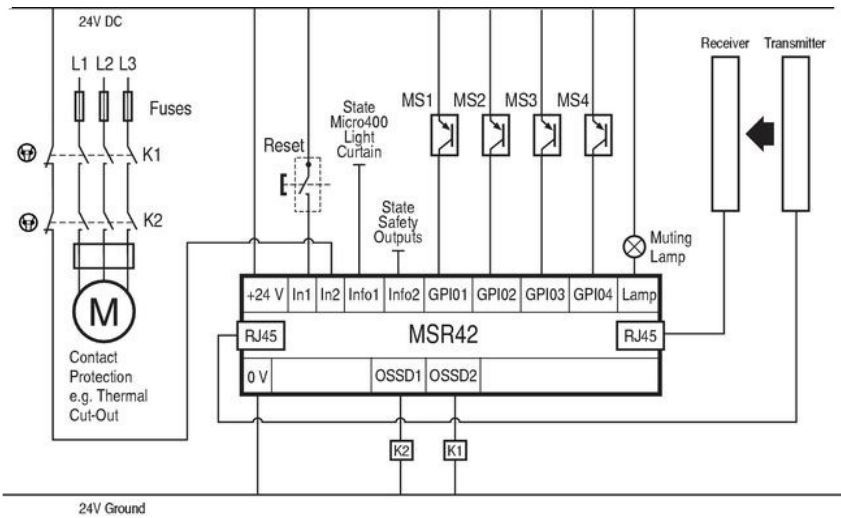

Note: Four Sensor T-type muting: GuardShield Micro 400, four muting PNP sensors, manual reset, output monitoring

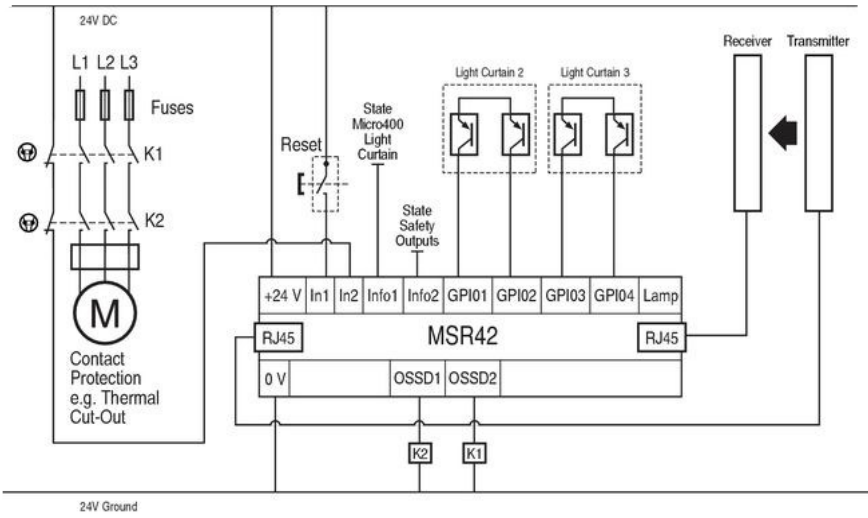

Note: Three-light curtain application: GuardShield Micro 400 light curtain, two GuardShield light curtains, manual reset, output monitoring

Application Details

MSR42—Shown connected to safety light curtains.

Multiple settings are available offering a variety of advantages.

Protective Mode

Example shows a press protected by a safety light curtain connected to the MSR42.

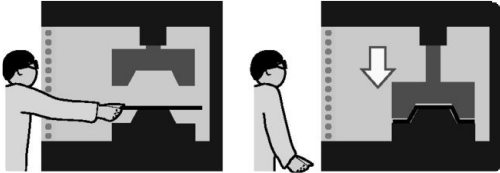

In machine operation, whenever the light curtain beams are broken the press immediately stops to help avoid danger to the operator. Once the beams are cleared the machine can then be started.

Muting Modes

Four conveyor examples: All conveyor applications shown with a safety light curtain helping protect the dangerous area. In-line and cross beam muting is used to allow the material to pass through the light curtain without stopping the machine. Any other object or person will be detected by the light curtain which will initiate machine stop.

Four Sensor T-type

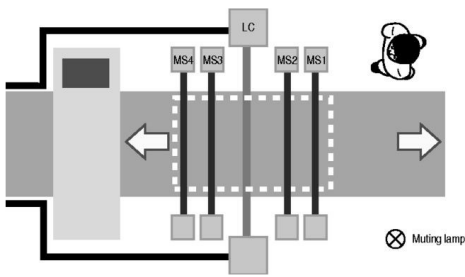

Bi-directional muting: In-line muting requires the material to break the beams in a sequence, as shown. Only if all four muting sensor (MS) beams are broken in turn and then clear in turn will the light curtain allow material through without initiating machine stop.

Two Sensor T-type

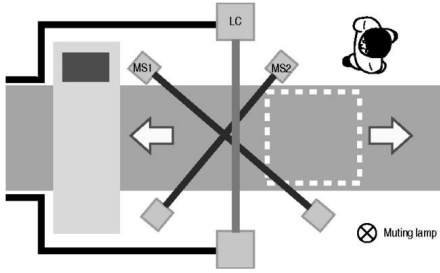

Bi-directional muting: Cross-beam muting requires the material to break the beams in a sequence. MS1 first and then MS2. Only if the beams are broken in turn and then clear in turn will the light curtain allow material through without initiating machine stop.

Two Sensor L-type

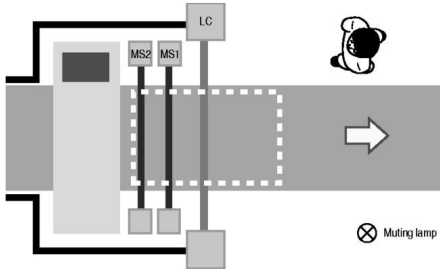

Uni-directional muting: This will allow material to exit the machine but not allow material or personnel to enter the machine without a fault condition. Only if both MS beams are broken in-turn and then cleared in-turn, will the light curtain allow material through without initiating a machine stop.

Two Sensor T-type with Enable

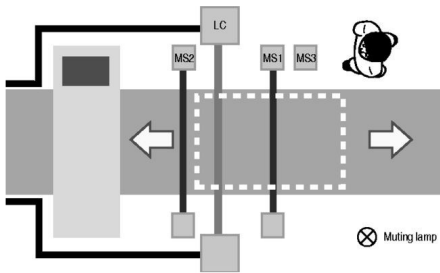

Bi-directional muting: The MS3 is an input to the MSR42 from a PLC output card. The MS3 enables the muting function to be performed. If a high signal is not detected on MS3, the muting function will not operate even if the MS1 and MS2 beams are broken. Only if MS3 is high and both MS beams are broken in-turn and then cleared in-turn, will the light curtain allow material through without initiating a machine stop.